

AIPHONE



GT SYSTEM

Video Fler-Bolig System

GT system is ideal for large scale residential Style mixed with IP technology. Enable



5000

**Aiphone's multi-bolig system
kan nu håndtere op til 5000 boliger.**

► P08

- Install one system for housing complexes with multiple buildings.
- Cover a building with more than 500 units with one system.

7-inch

Designet til endnu nemmere brug.

► P05

- Bolig svarstationen fås nu også med 7" knivskarpt billed visning.
- Kompakt og intuitive funktionel design.



**IP og NFC teknologier gør
effektive brug og drift muligt.**

► P09

- Bygningsdrift fra hvorsomhelst via IP netværks forbindelse.
- Indbygget NFC læser for let programmering og beboer administration.

developments with multiple buildings.
creation of new solutions.



Flere
samhørende
bygninger



Stor skala
beboelses
ejendomme



Lukkede
bolig/villa
område

GT-1C7



Svar Station

7-tommer display (GT-1C7)

7-inch

- Høj-opløsning, 7-tommer display gør gæsterne nemme at genkende.
- Funktional design, intuitiv kontrol: bagbelyste lette-at-se taster for døråbning og kommunikation ved opkald fra dørstationen.

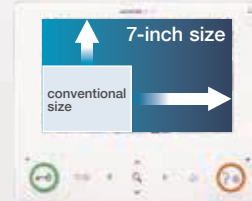

Vidvinkel / Zoom & PanTilt



Tydeligt billed visning

ca. **170°**

- Panoramisk Vidvinkel visning
For at give en effektiv sikkerhed har GT System et vidvinkel kamera, der gør det muligt at se en klar panoramavisning. Se og identificere besøgende, der står på siderne og folk i alle højder.



Vidvinkel visning



Zoom visning



PanTilt visning (kun GT-1C7 og GT-2C)

Dør åbning

- Bekræft besøgenes identitet og åbn derefter indgangen fra svarstationen.

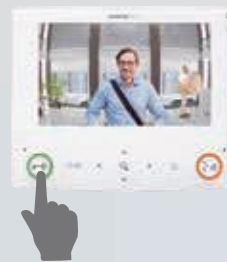

ÅBEN

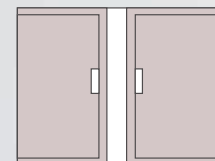

Udvælgelse af svarstationer til ethvert behov



- GT-1C7**
Svarstation med farve skærm
- 7-tommer display
 - Hånd-fri betjening



- GT-1M3**
Svarstation med farve skærm
- 3.5-tommer display
 - Hånd-fri betjening



- GT-2C**
Svarstation med farve skærm
- 3.5-tommer display
 - Billed optager
 - Dørstation ved egen dør muligt
 - Telefonrør kan eftermonteres (GT-HS)



- GT-1A**
Audio svarstation
- Hånd-fri



- GT-1D**
Audio svarstation
- Med Rør

Dør Stationer

Alt-i-én type / Modul type



Panorama vidvinkel & klart farve billed



- 170 ° vidvinkel kamera.
- Hvid lysdiode tænder automatisk ved for svagt lys.

Mulighed for ekstra kamera for øget sikkerhed

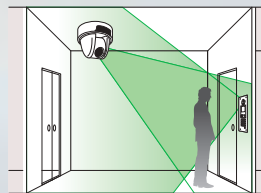

- Tilslut et ekstra CCTV kamera. Du kan vælge et af kameraerne placeret ved indgangen til overvågning. Dette giver dig mulighed for at bekræfte besøgendes identitet fra forskellige vinkler, hvilket gør det nemmere at forhindre mistænkelige personers indtrængen.

NFC Læser



- Brug NFC-læser eller adgangskoder til låsekontrol.
- NFC-læseren kan også bruges til programmering af systemet. (→ P.09)

2 panel typer

- 2 stilarter at vælge imellem:
- Alt-i-én type eller modul type.
- Modultype gør kun Audio muligt samt andre konfigurationer.



Alt-i-én type



Module type

Vagt Station



3.5-tommer display

- Let betjening af alle vagt funktionerne.
- Video monitoring af dørstationer.

Vidvinkel / Zoom & PanTilt

- Se videobilled i 170 ° bredde af indgangskameraet.
- Brug zoom og pan tilt-funktioner til en detaljeret visning.

Receptions funktion

- Using this function, all entrance station calls are automatically transferred to the guard station, giving the security guard the ability to screen visitors.

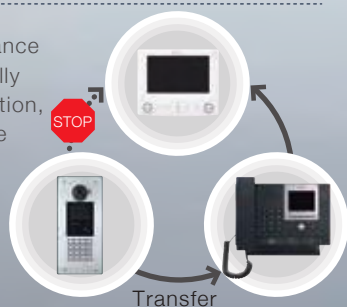

Kan forbinde en individuel video dør station (JO-DV)

- Automatisk LED lys tænding i svagt belyste montage områder.



JO-DV

System Variationer

Enkel bygnings system

- Ideel til små og mellemstore bygninger.
- Både Audio og Video løsning mulig.

Maksimum Kapasitet

	Bolig typer	
	Standard system	Udvidet system
Dør-stationer	5	16
Vagt-stationer	2	4
Bolig-stationer	48*1	500

*1: Op til 100 GT-1D audio bolig stationer kan monteres i en kun Audio installation.

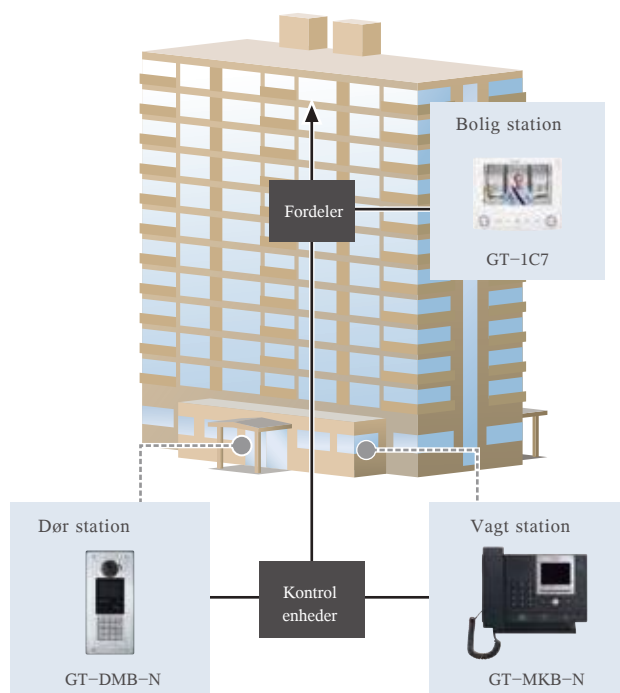

5.000

Multi bygnings system

- Installer ét system til boligkomplekset med flere bygninger.
- Hver bygning med mere end 500 enheder i ét system.
- Bygningsadministration fra hvor som helst via en IP-netværksforbindelse.
- Både Audio og Video løsning mulig.

Maximum Kapasitet (Antal stationer er pr. Bygning / sektion)

	Bolig ejendomme		Hoved bygning	
	Standard system	Udvidet system	Standard system	Udvidet system
Dør station	4	15	4	15
Vagt station	1	3	1	3
Bolig station	48	500	—	—

Total maximum capacity

(Total for tenant building / section and main building / section)

Dør station	480
Vagt station	96
Bolig station	5000

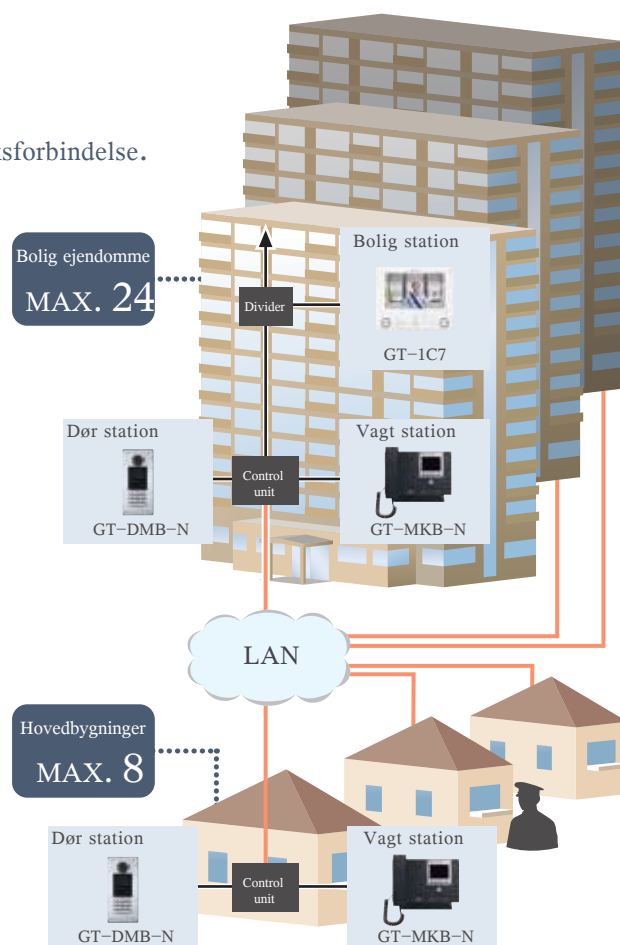



IP teknologi

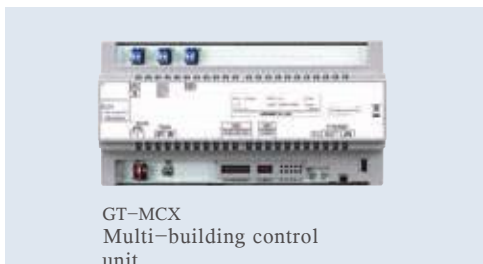

- Flere boliger og hovedbygninger kan tilsluttes via et IP Netværk for at skabe et multi-bygningssystem for central administration.
- Der kan højst tilsluttes 24 bolig bygninger og 8 hovedbygninger.
- Flere bolig bygninger kan kombineres for hver at rumme mere end 500 boliger hver.
- Binder bygninger sammen og giver mulighed for kommunikation på tværs af bygninger.

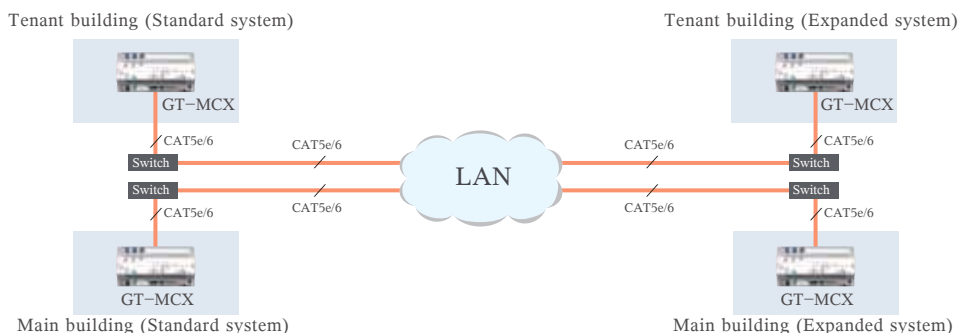

System programmering og NFC teknologi

Let og enkel opsætning via Pc'er eller Android mobilenhed

- Opsætning udføres på Pc'er eller Android mobilenhed gennem GT Setup Tool software / App.
- Understøtter OS: Windows 7, 8.1, 10.*1
- Understøtter Android OS version: Android 5.0 og nyere.



GT Setup Tool til Windows



GT Setup Tool til Android

Overførsel af opsætnings og system data

Overførsel af opsætning via Android mobil enhed til GT-DMB-N, GT-DB-VN, GT-MKB-N, GT-BCXB-N (W/NFC læser)

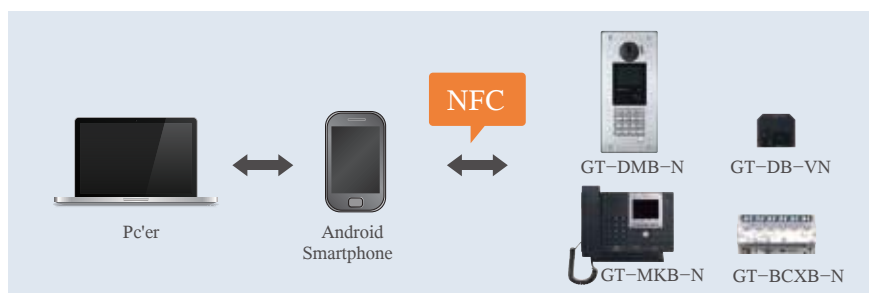

Forbind enheden til en Pc'er via USB

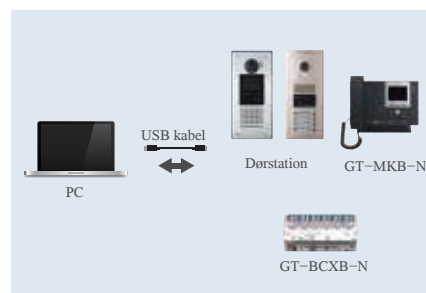

Overførsel af opsætning gennem en netværks forbindelse

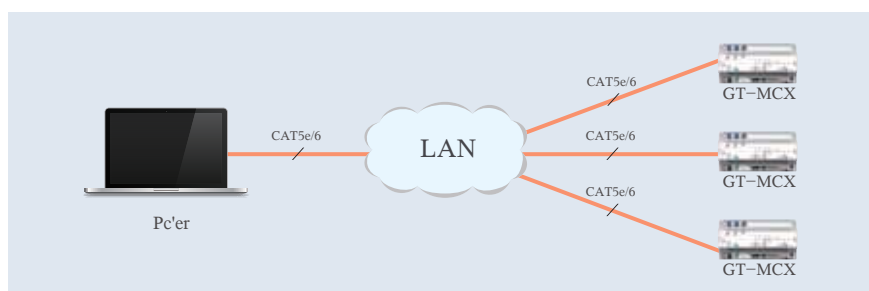

Sammenkopling af flere bygninger

Installations eksempel

F.eks. 4 bolig blokke (4 Dørstationer, 4 Vagt stationer, 1,060 Bolig svarstationer)

2 Hovedbygninger (2 Dørstationer, 6 Vagt stationer)

- Kan konfigureres som et enkelt system uden at skabe separate systemer til hver bygning.
- Tilslut bygninger gennem et IP-netværk. Ideel til store steder med lange afstande mellem bygninger.
- Hovedbygningen kan kommunikere med alle bygninger & boliger.

Foreslået system:

1 Standard system, 3 Udvidede systemer i boligbygninger.

2 Udvidede systemer i hovedbygninger. (Maksimal kapacitet → Side 8)

* Mulighed for at blande video- og kun audio enheder i et sammenhængende system.

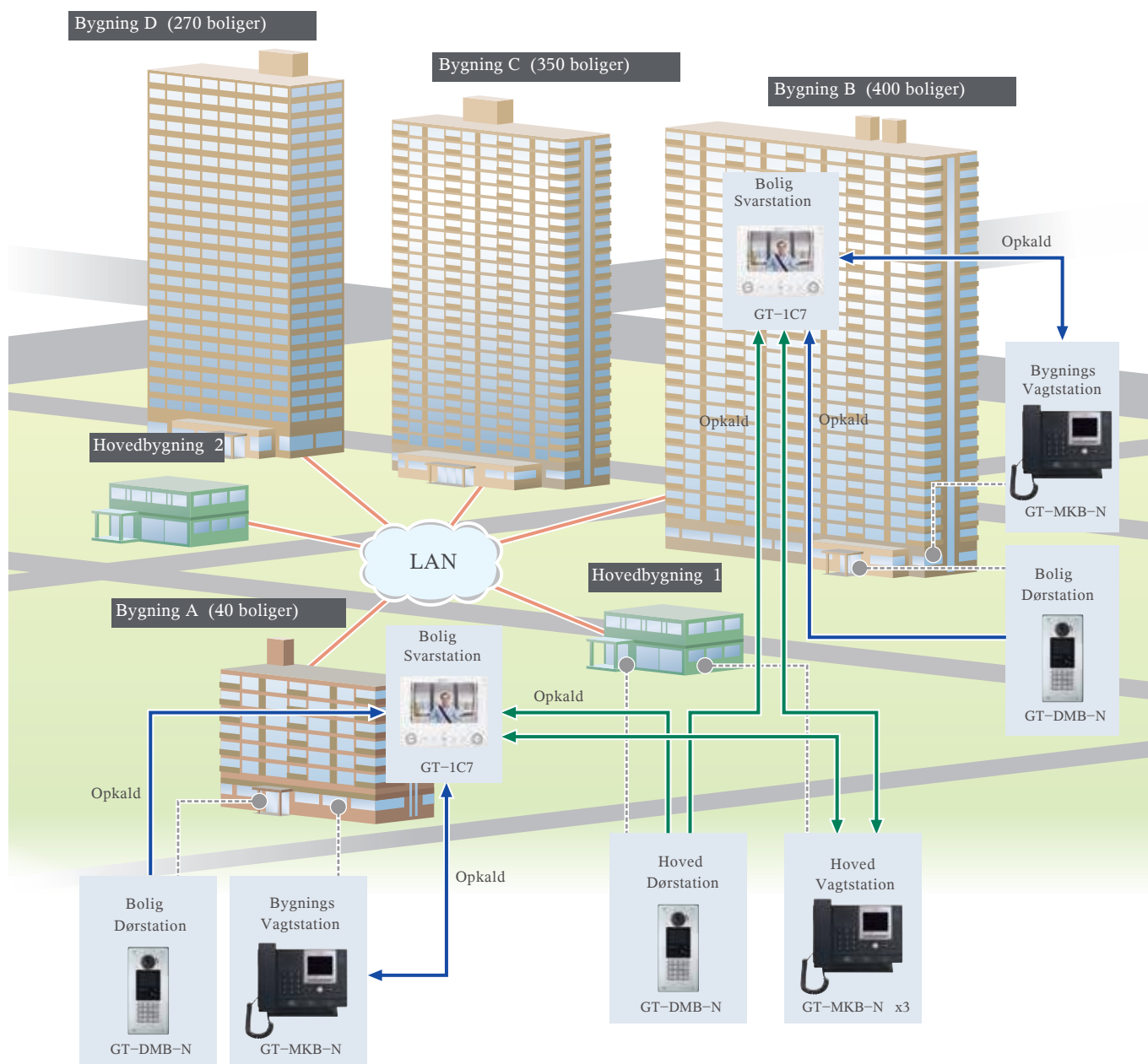

Bygning A, B, C, D: I ovenstående eksempel betyder bolig-bygninger og tårne.

Hovedbygning 1 & 2: I ovenstående eksempel betyder bygninger såsom sikkerhedscentre og administrative, kontor, fællesfaciliteter etc.

System konfigurations eksempel

Ikke oversat!

Tenant building A: 40 units (Standard system)

Total max. wiring distance is 2,500m.
Do not mix wiring methods within individual trunk lines.

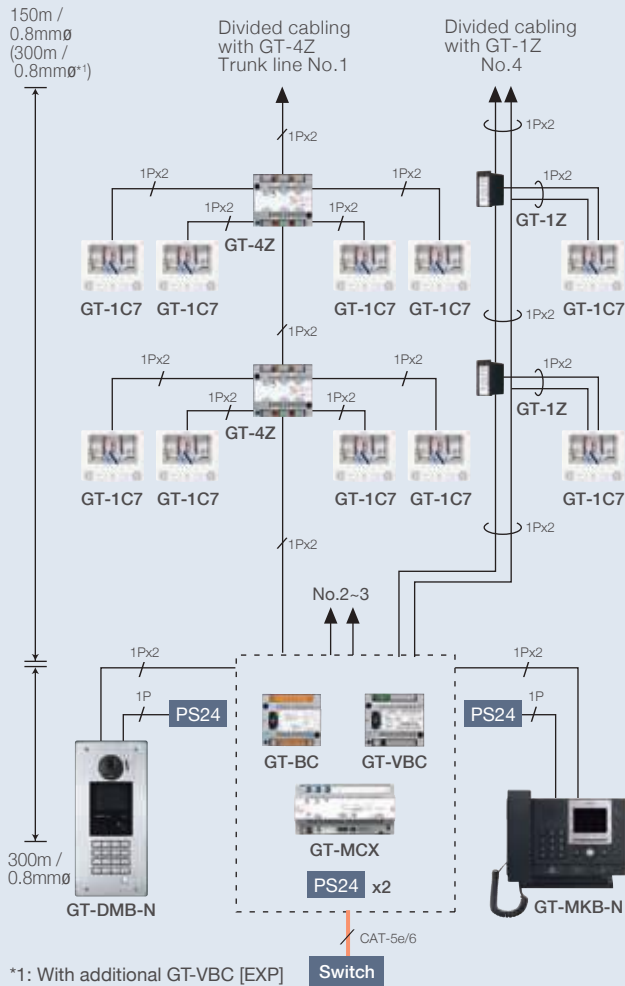

Tenant building B: 400 units (Expanded system)

4 sub trunk lines (SUB1A, 1B, 2A, 2B)
Max. 125 Tenant stations and max. 2,500m wiring distance for each sub trunk line. Total max. wiring distance is 10,000m.
Do not mix wiring methods within individual trunk lines.

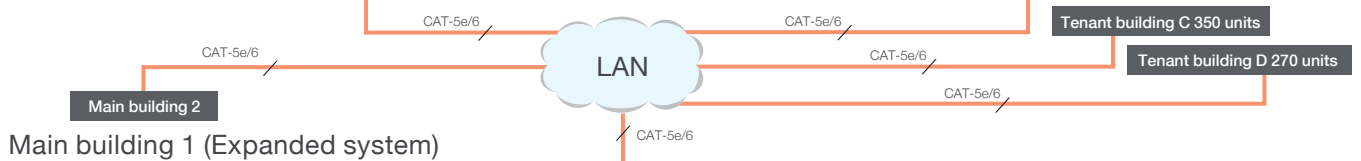
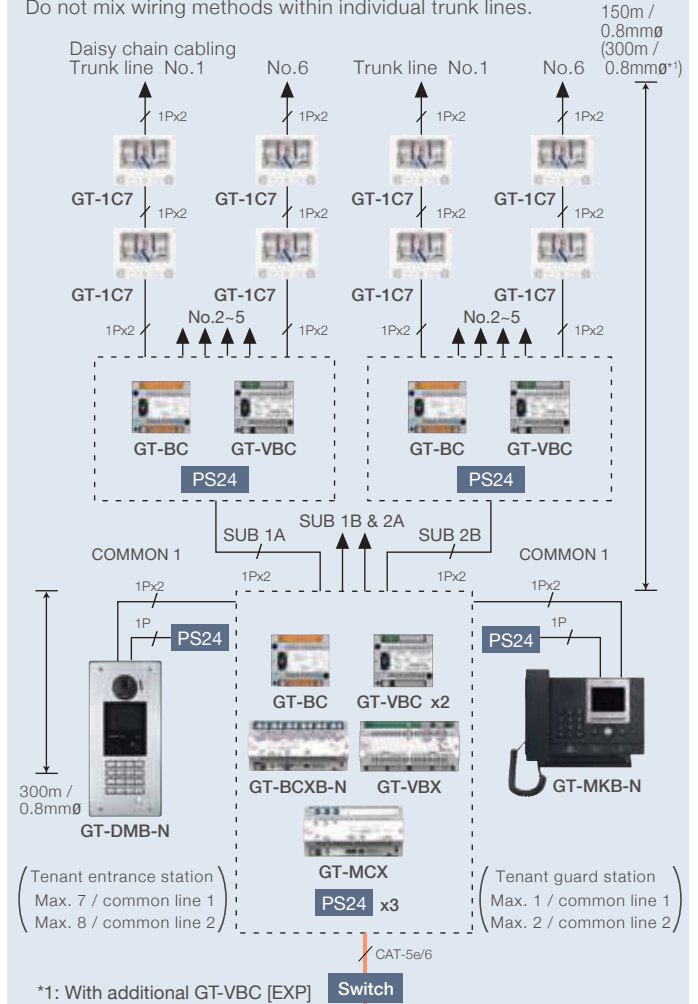

Main building 1 (Expanded system)

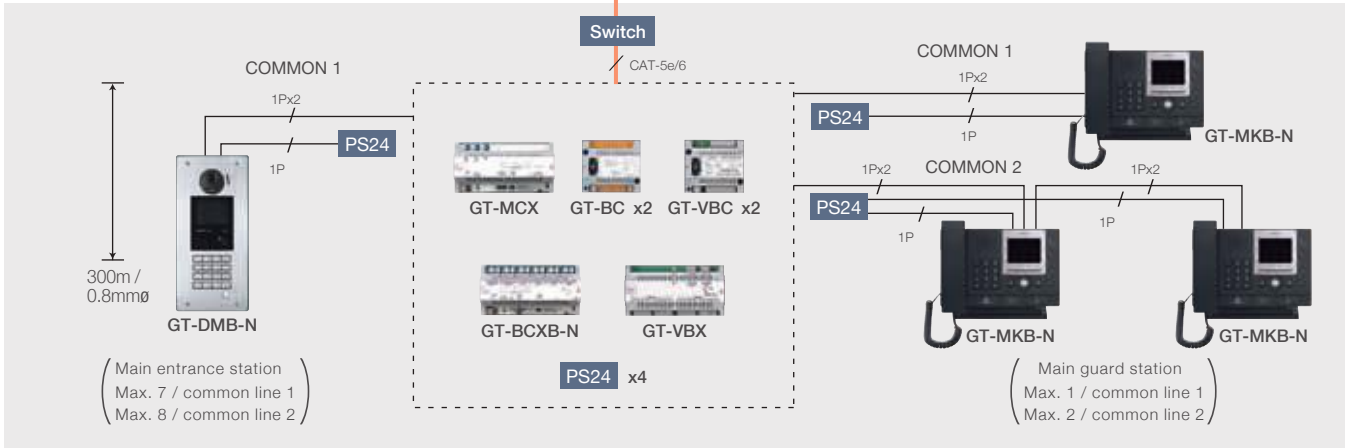

*Cable: 1Px2, 2-conductor cable solid copper & non-braided, polyethylene insulation.

Large Scale Residential Building (more than 500 units)

Installation example

e.g. 3 Tenant sections (1,100 Tenant stations)

1 Main section (3 Entrance stations, 3 Guard stations)

- Multi-building control units allow systems to be configured without having to use separate systems for each section.
- All tenant stations can be called from any entrance station or guard station.

Proposed system:

3 Expanded systems in tenant sections

1 Expanded system in main section

(Maximum capacity → P.08)

*Possible to mix video and audio only systems.

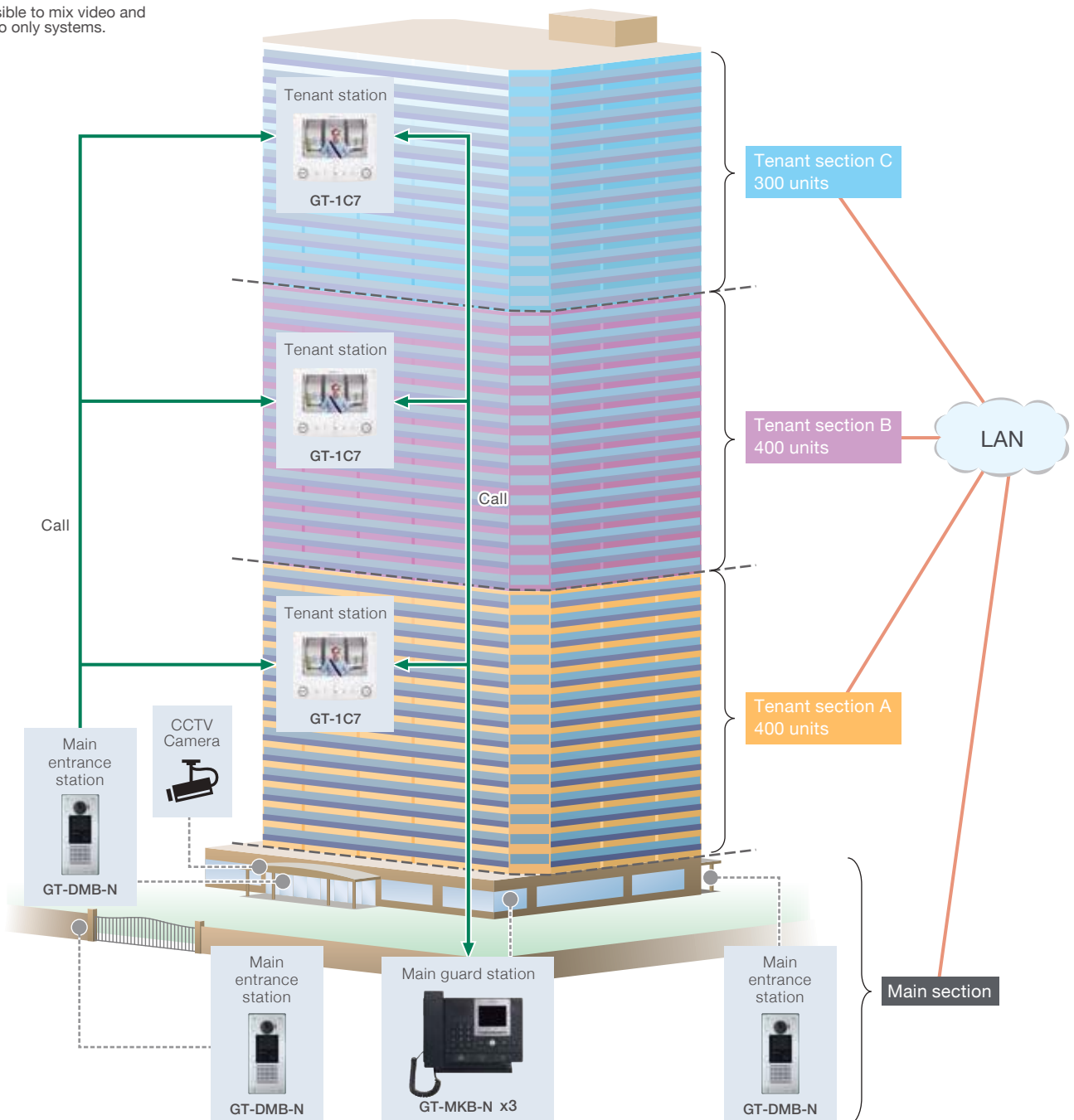

Main section: In the above example, main section means lobby and main entrance.

System configuration example

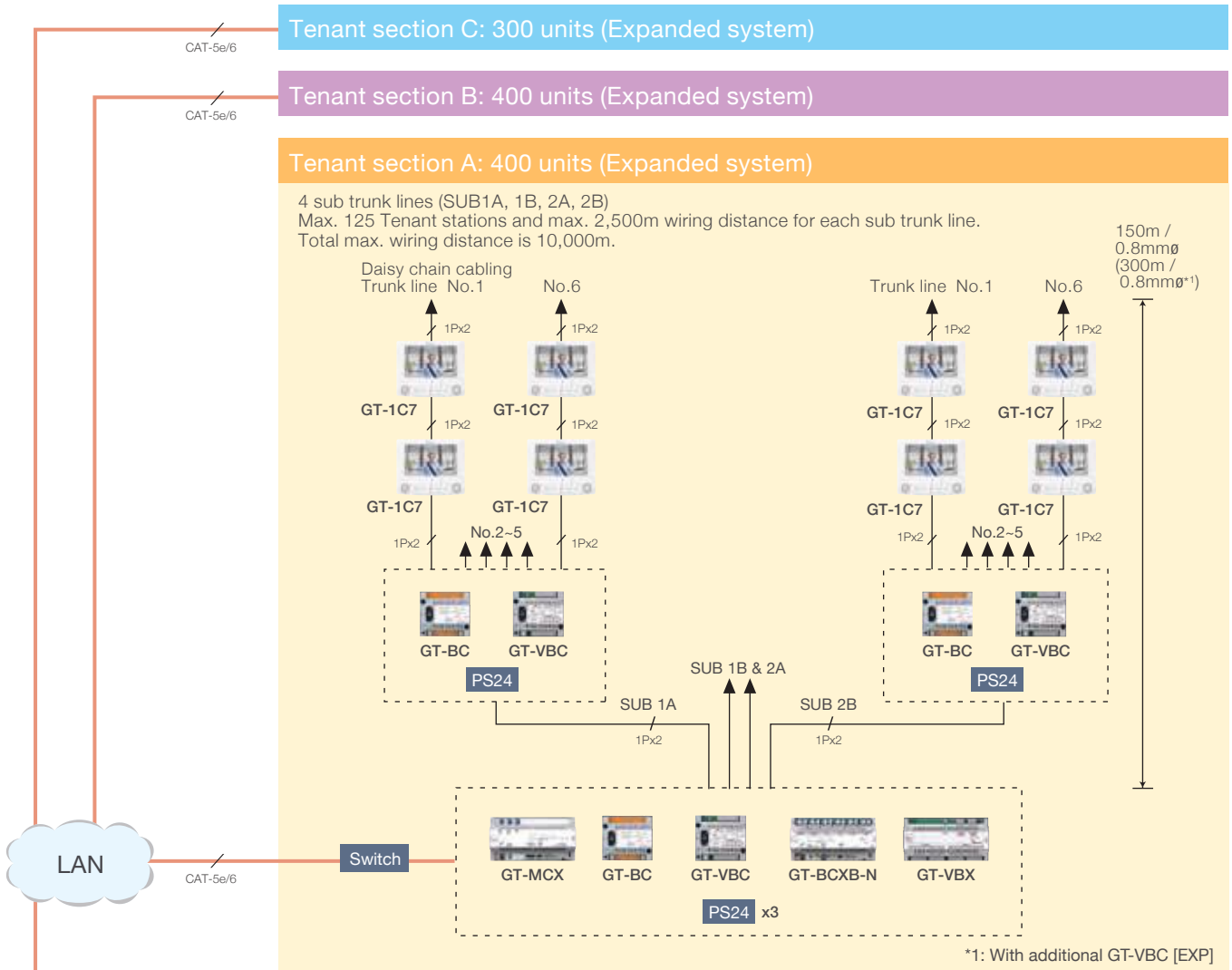

Main section (Expanded system)

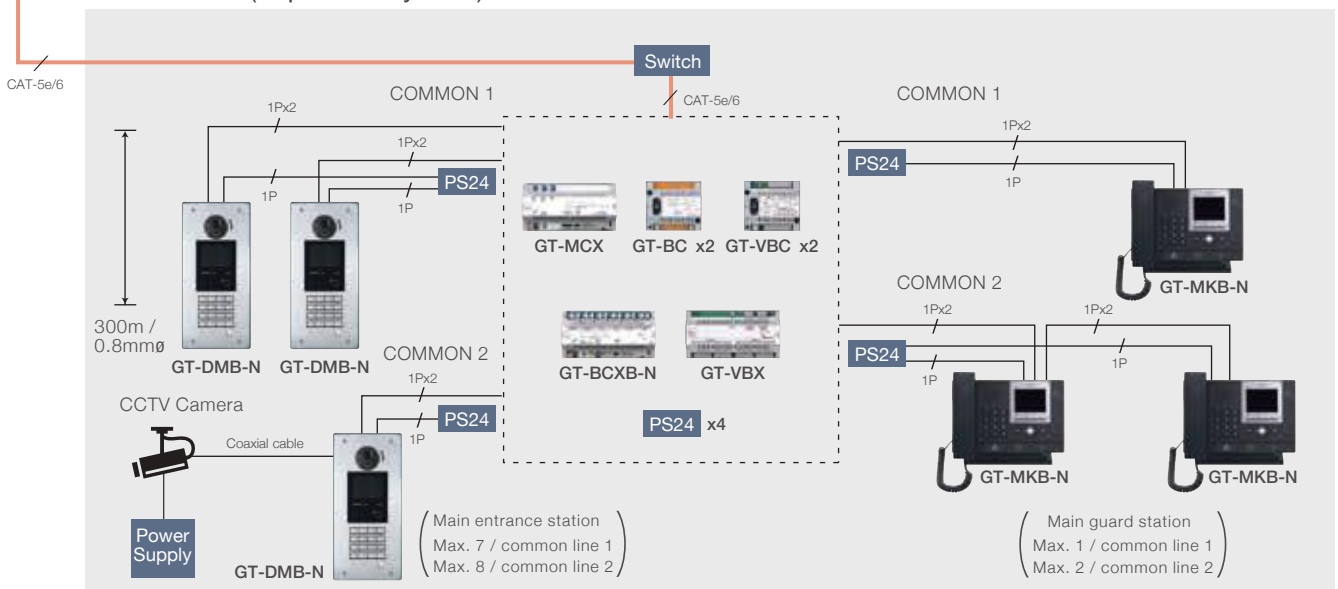

*Cable: 1Px2, 2-conductor cable solid copper & non-braided, polyethylene insulation.

Gated Community / Villa

Installation example

e.g. 2 Tenant sections (60 Tenant stations)

1 Tenant building (1 Entrance station, 1 Guard station, 400 Tenant stations)

1 Main section (1 Guard station)

- All sections (buildings) can be configured in a single system without creating separate systems for different types of buildings.
- Connect sections through an IP network. Ideal for large sites with long distances between sections.
- The main section can communicate with all tenant sections.

Proposed system:

2 Standard systems in tenant sections.

1 Expanded system in tenant building.

1 Standard system in main section. (Maximum capacity → P.08)

*Possible to mix video and audio only systems.

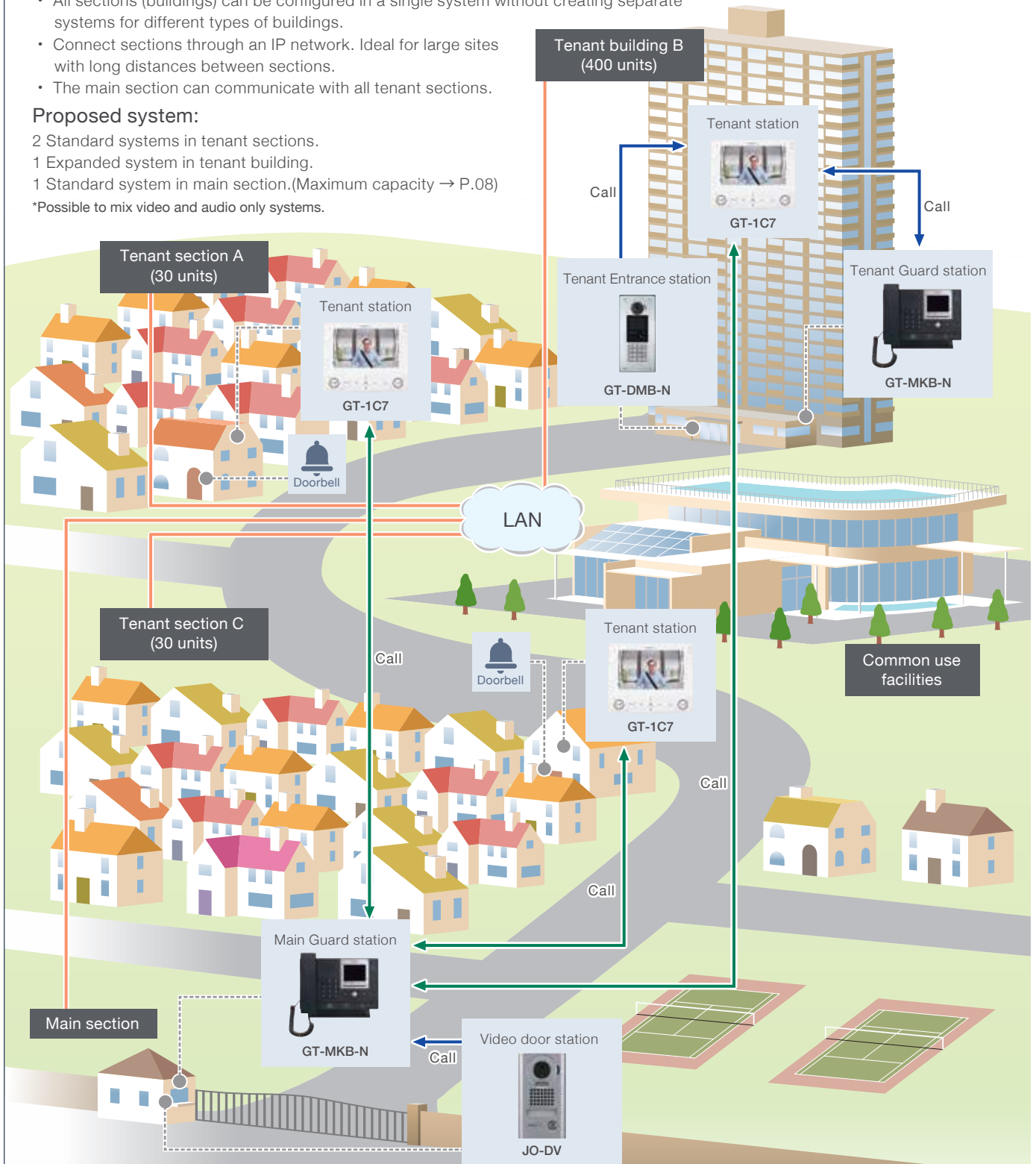

Tenant section A, C: In the above example, tenant sections mean individual housing sections.

Tenant building B: In the above example, tenant building means residential tower.

Main section 1: In the above example, main section means buildings such as security centers and administrative offices.

System configuration example

Tenant section A & C: 30 units (Standard system)

Total max. wiring distance is 2,500m.
Do not mix wiring methods within individual trunk lines.

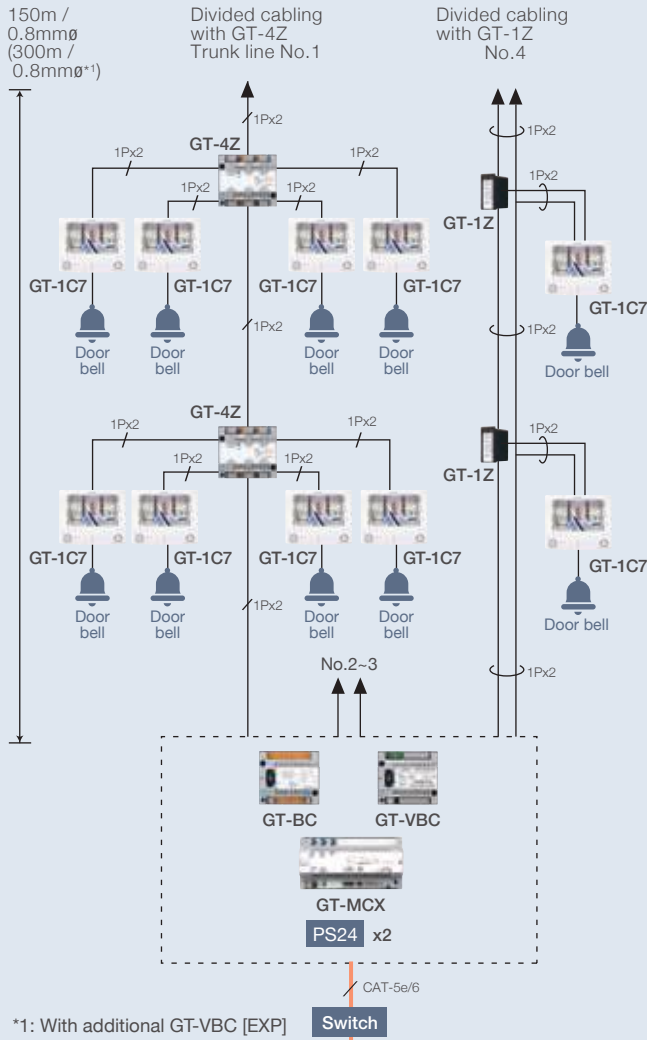

Tenant building B: 400 units (Expanded system)

4 sub trunk lines (SUB1A, 1B, 2A, 2B)
Max. 125 Tenant stations and max. 2,500m wiring distance for each sub trunk line. Total max. wiring distance is 10,000m.
Do not mix wiring methods within individual trunk lines.

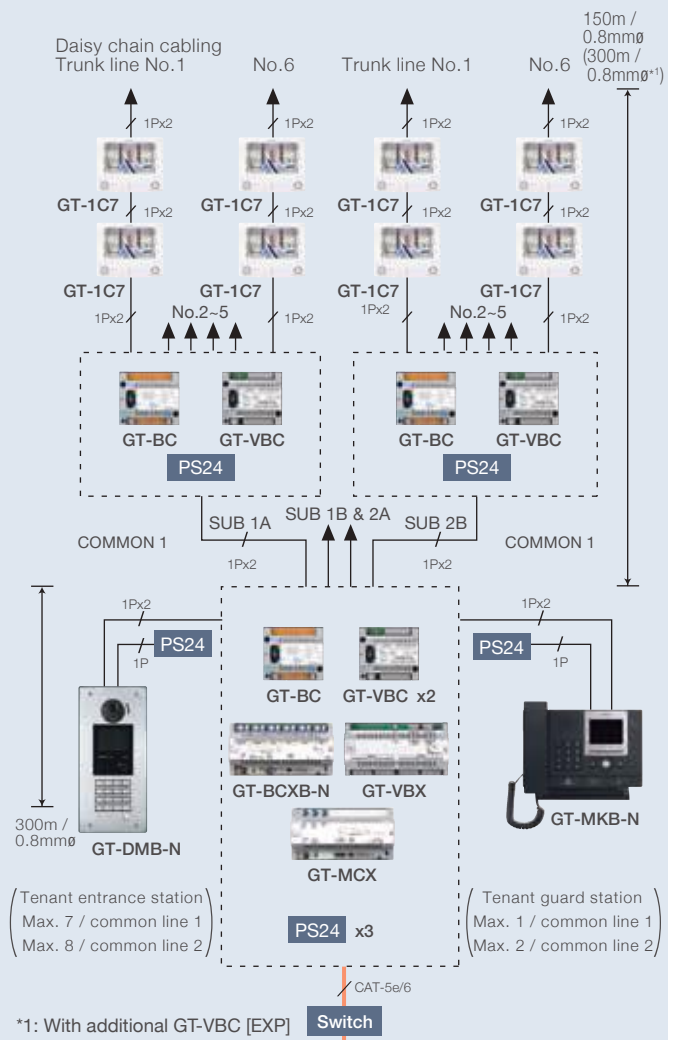

Main section (Standard system)

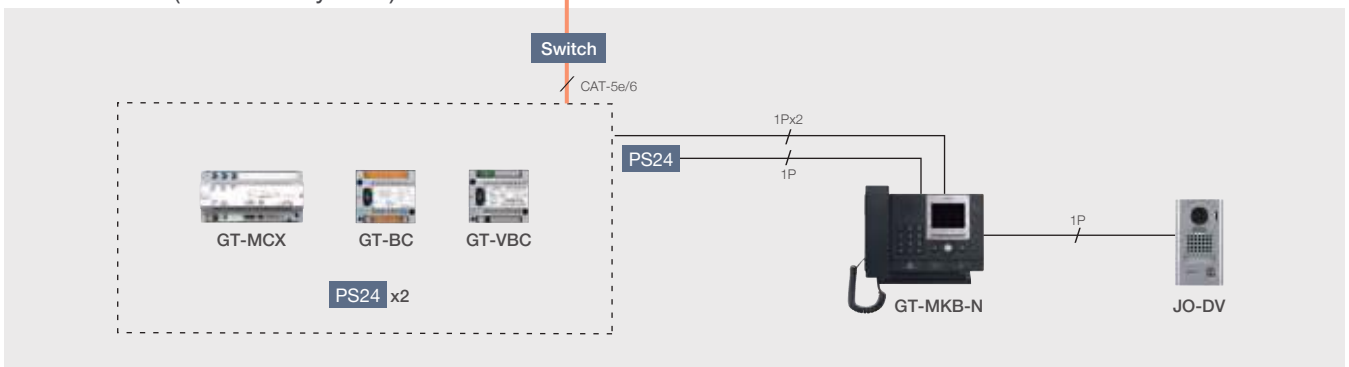

*Cable: 1Px2, 2-conductor cable solid copper & non-braided, polyethylene insulation.

Installation example

e.g. 1 Tenant building (1 Entrance station, 1 Guard station, 20 Tenant stations)

Proposed system:

- 1 Standard system in tenant building.
- (Maximum capacity → P.08)
- *Possible to mix video and audio only tenant stations.

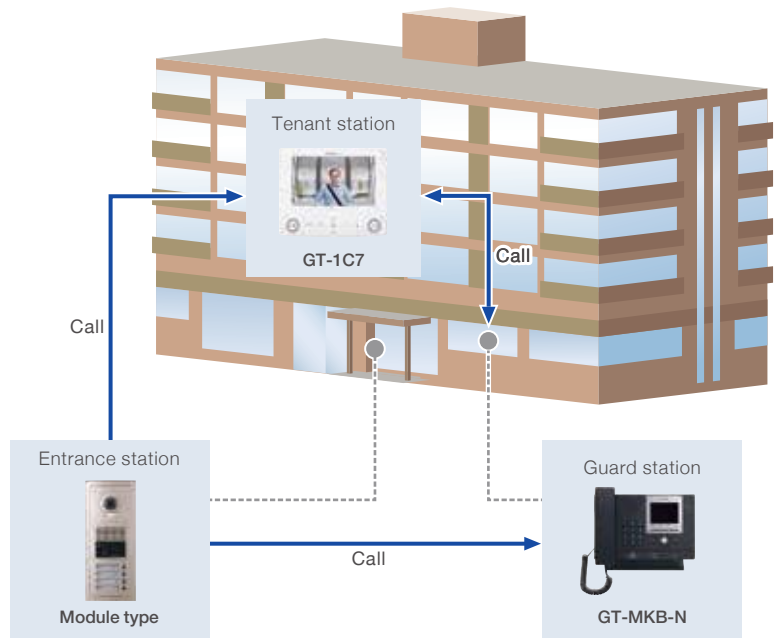

System configuration example

Total max. wiring distance is 2,500m.

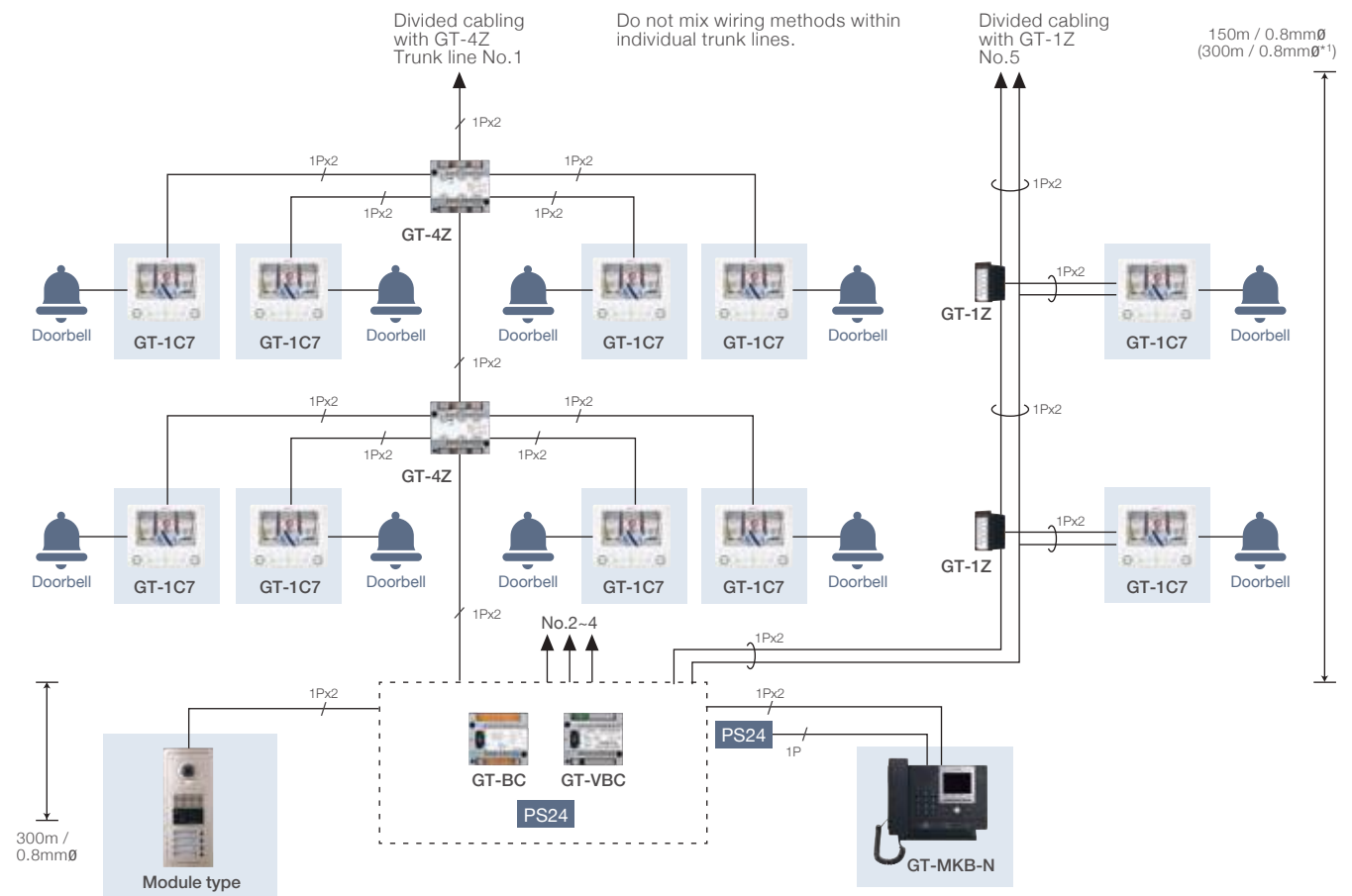

*Cable: 1Px2, 2-conductor cable solid copper & non-braided, polyethylene insulation.

*1: With additional GT-VBC [EXP]

Installation example

e.g. 1 Tenant building (2 Entrance stations, 2 Guard stations, 150 Tenant stations)

Proposed system:

1 Expanded system in tenant building.
(Maximum capacity → P.08)

*Possible to mix video and audio only tenant stations.

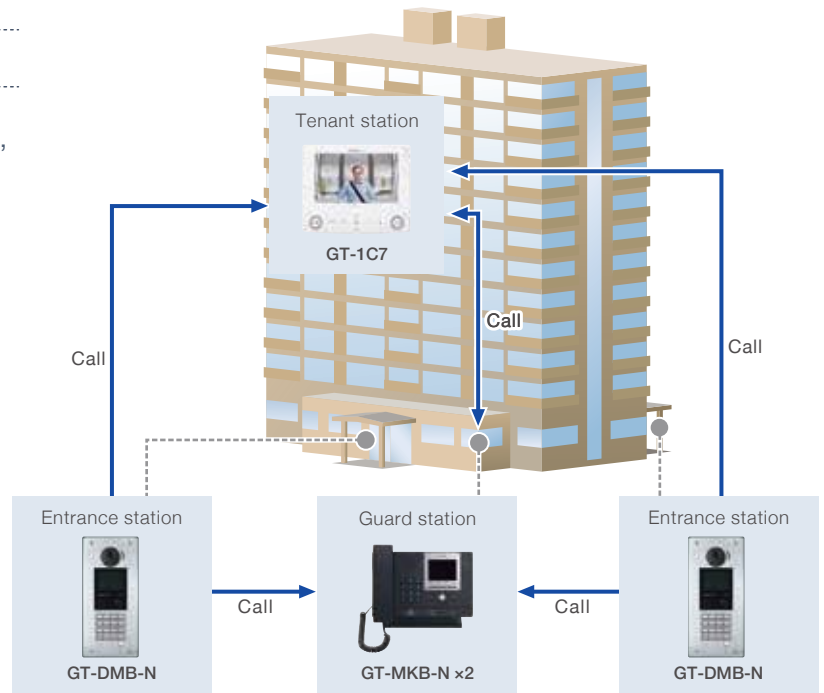

System configuration example

4 sub trunk lines (SUB1A, 1B, 2A, 2B)
Max. 125 tenant stations and max. 2,500m wiring distance for each sub trunk line.
Total max. wiring distance is 10,000m.

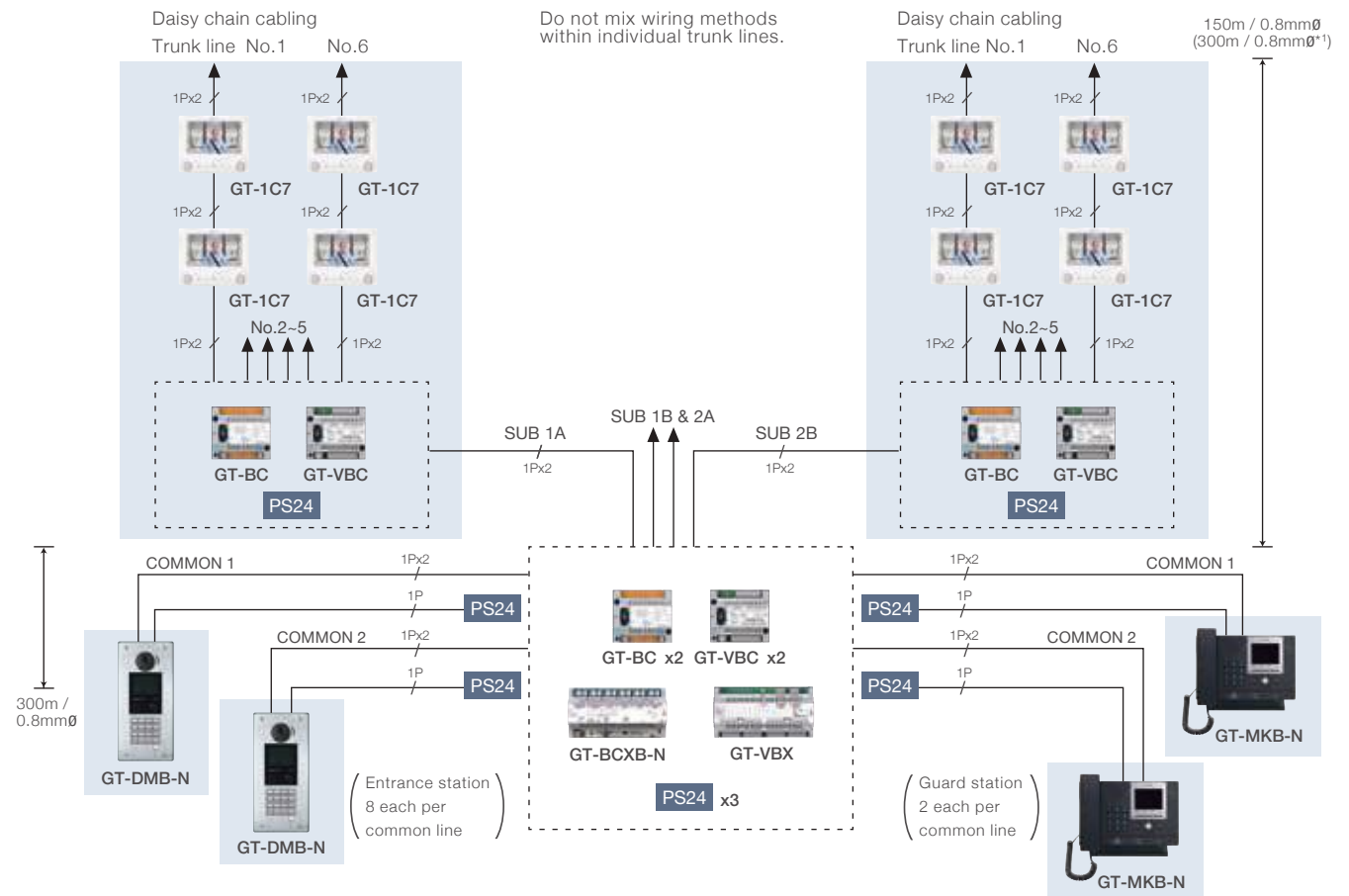

*Cable: 1Px2, 2-conductor cable solid copper & non-braided, polyethylene insulation.

*1: With additional GT-VBC [EXP]

Dørstationer

Alt-i-én type dørpanel



GT-DMB-N
Dørstation
W/NFC Læser
(Bag boks ikke inkluderet.)
Benyt GF-3B.

- 170° vidvinkel kamera.
- Talt og visuel vejledning for at give besøgende status og driftshjælp gennem et opkald.
- Vælg navne eller numre ved hjælp af tastaturet.
- Brugerdefinerede og programmerbare velkomstmeldelser kan vises i displayet.
- 9 sprog (engelsk, fransk, tysk, spansk, nederlandsk, italiensk, norsk, tyrkisk og finsk) er tilgængelige for meddelelser i skrevet vejledning.
- 6 sprog (engelsk, fransk, tysk, spansk, nederlandsk og norsk) er til rådighed for talte lydvejledning.
- Hvidt lysdiode lyser automatisk ved for svagt lys.

Modul type dørpaneler



Front ramme & bag boks



GT-4F
4-modul front ramme
GF-3F
3-modul front ramme
GF-2F
2-modul front ramme

GT-4B
4-modul bag boks
GF-3B
3-modul bag boks
GF-2B
2-modul bag boks

Kamera Modul



GT-VP
Kamera panel



GT-VB
Kamera modul
for GT-DB(-VN)

Opkaldstryk Moduler



GF-1P
1-kald panel



GF-2P
2-kald panel



GF-3P
3-kald panel



GF-4P
4-kald panel



GT-SW
kald switch modul

Audio Modul



GT-DBP
Audio panel
for GT-DB(-VN) W/O NFC læser



GT-DB*1
Audio modul
for GT-DB(-VN) W/O NFC læser



GT-DB-VN*1
Audio modul
W/NFC læser

Digital name scrolling module



GT-NSP-L
Display modul
panel



GT-NSB
Digital navne scroll
display modul
for GT-DB(-VN)



GF-10KP
10-tryk
modul panel



GT-10K
10-tryk modul

Adgangskontrol modul



GT-AC
Access control keypad
module

Tilvalg



GF-AP
Address module
panel



GT-AD
Address module



GF-BP
Blank panel



GT-nH
Regn skærm
for indbygning



GT-nHB
Påbygnings boks-
for påbygning

* 1: GT-DB og GT-DB-VN kan ikke benyttes i hovedbygningerne i et flerbyggesystem.

Vagt station



GT-MKB-N
Guard station

Strømforsyning



PS-2420S



PS-2420D

Bolig svarstationer



GT-1C7
7" Svarstation



GT-1M3
3 1/2" Svarstation



GT-2C
3 1/2" Svarstation



GT-1A
Audio Svarstation



GT-2H
3 1/2" Under Svarstation for GT-2C



GT-HS
Telefonrør
for GT-2C og GT-2H



GT-1D
Audio Svarstation

Dørstation

Video dørstationer for GT-2C



JK-DA
Vidvinkel / Zoom & PanTilt
video dørstation,
for påbygning



JK-DV
Vidvinkel / Zoom & PanTilt
Vandal sikker video dørstation,
for påbygning



JK-DVF
Vidvinkel / Zoom & PanTilt
Vandal sikker video dørstation,
for indbygning

Dørstation kun for GT-2C



GT-D
Audio only door
station, surface mount

Video dørstation for GT-MKB-N



JO-DV
Vandal sikker
video dørstation,
for påbygning



Tilvalg



GT-RY
Relæ for trappelys
eller ekstra signalgiver,



AC-10S
Kodetastatur
for påbygning



AC-10F
Kodetastatur
for indbygning

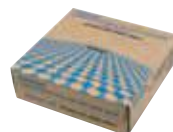

AE7090220B AE7090220G
AE7090210B AE7090210G
AIPHONE godkendt installationskabel

Kontrol enheder

Basis kontrol enheder



GT-BC
Bus control unit



GT-VBC
Video bus control unit,
expander video control



GT-4Z
4-way video
junction unit



GT-1Z
Video 1-zone
divider

Kontrolenheder for udvidet system



GT-BCXB-N
Udvidet BUS kontrol enhed



GT-VBX
Udvidet Video BUS kontrol enhed

LAN-IP kontrol enhed



GT-MCX
LAN-IP kontrol enhed

Elevator kontrol enhed



GTW-LC
Elevator kontrol adapter

Dimensioner på enhederne (mm)

Dørstationerne

GT-DMB-N (med GF-3B)

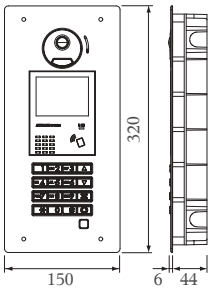

Audio / Video + Navne scroll (med GT-4B)

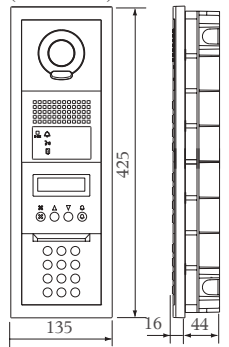

4-call (med GF-3B)

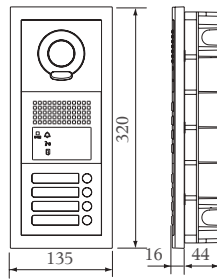

Audio / Video + Navne scroll (med GF-2Bx2)

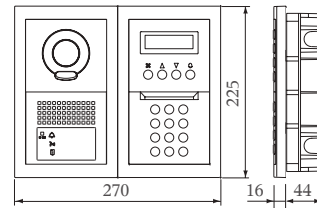

GT-VP

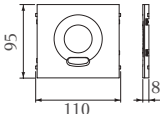

GT-VB

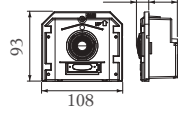

GF-4P

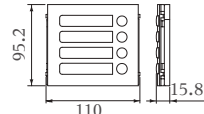

GT-SW

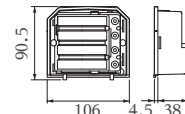

GT-NSP-L

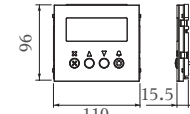

GT-NSB

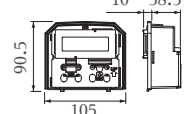

GT-DBP

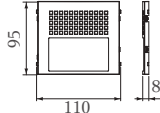

GT-DB / GT-DB-VN

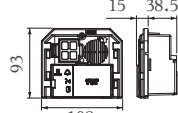

GF-10KP

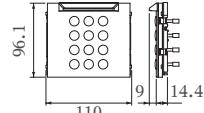

GT-10K

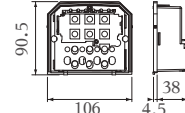

GT-AC

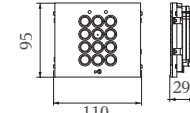

GT-4F

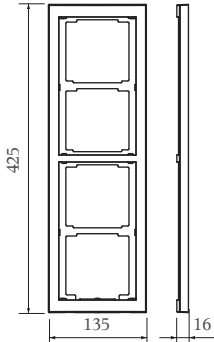

GT-4B

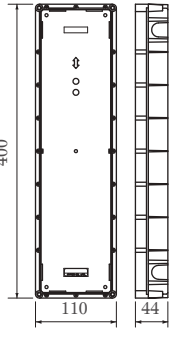

GT-104H

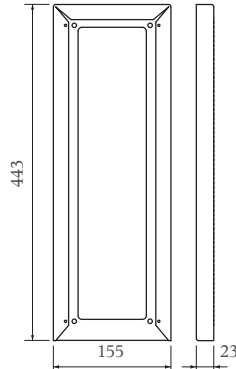

GT-104HB

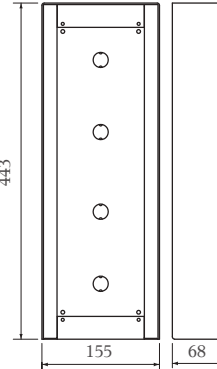

billed visnings områder

Vidvinkel

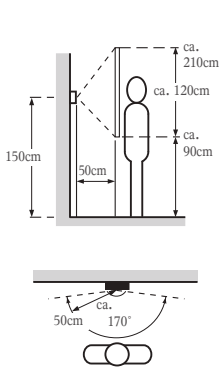

ZOOM & PanTilt

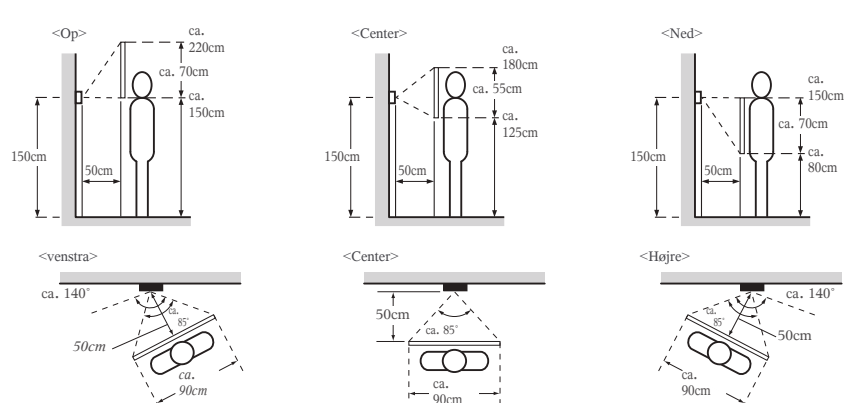

Vagt stationen

GT-MKB-N

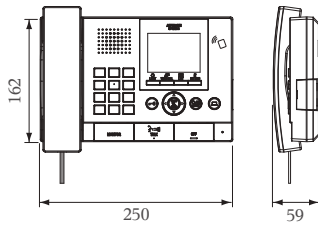

Strømforsyning

PS-2420S,
PS-2420 DIN (8 moduler)

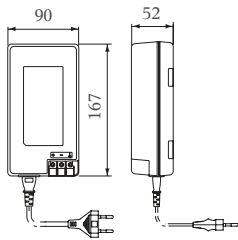

*Ledning & stik leveres ikke med PS-2420 DIN strømforsyningen.

Svar stationer

GT-1C7

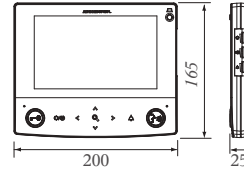

GT-1M3

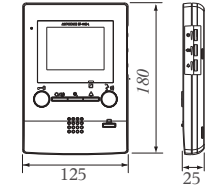

GT-2C, GT-2H

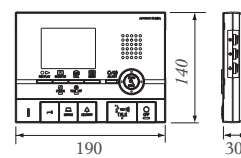

GT-HS

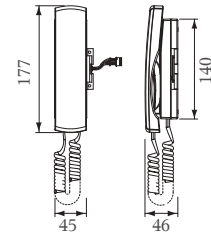

GT-1A

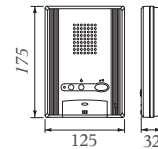

GT-1D

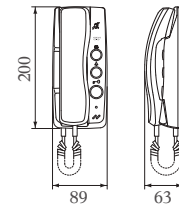

Dør stationer

JK-DA

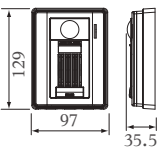

JK-DV

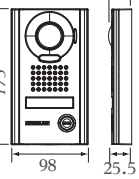

JK-DVF

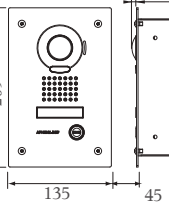

GT-D

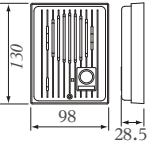

JO-DV

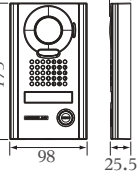

Kontrol enheder

GT-BC, GT-VBC, GT-4Z

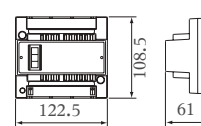

GT-1Z

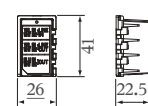

GT-BCXB-N

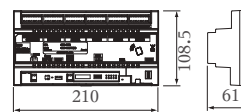

GT-VBX

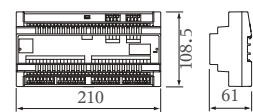

GT-MCX

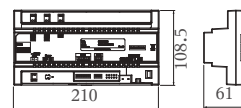

GTW-LC

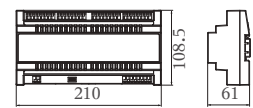

Elevator kontrol adapter GTW-LC

Med elevator kontrol adapteren bliver det muligt at kontrollere elevator til etage.



GT-1C7

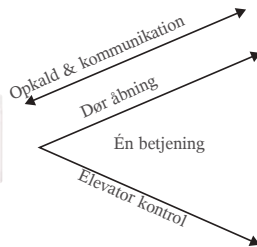

Dørstation

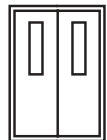



Elevator

** GT-BCXB-N er nødvendig når GTW-LC benyttes.
** GTW-LC kan kun bruges multi bygnings system.

Hånd-Fri Farve Video Multi-Bolig Bygnings System med Zoom & PanTilt

Antal systemkomponenter efter systemtype







Antal nødvendige kontrolenheder ved maksimal lejemål og fælles udstyrskapacitet.

	Bygning / Sektions type	System type	VIDEO / AUDIO	Max. Bolig stationer	Max. Dør stationer		Max. Vagt stationer
					 GT-DMB-N	 Modul type	 GT-MKB-N
Enkel bygnings system (Max. 500 boliger)	Bolig bygning	Standard	VIDEO	48 *1	5		2
			AUDIO	100 *2	5		2
		Udvidet	VIDEO	500 *1	16		4
			AUDIO	500	16		4
Multi bygnings system (Max. 5000 boliger)	Bolig bygning (Max. 24 bygninger)	Standard	VIDEO	48 *1	4		1
			AUDIO	100	4		1
		Udvidet	VIDEO	500 *1	15		3
			AUDIO	500	15		3
	Hoved bygninger (Max. 8 bygninger)	Standard	VIDEO	×	4	×	1
			AUDIO	×	4	×	1
Udvidet	VIDEO	×	15	×	3		
	AUDIO	×	15	×	3		

*Antal boliger, enheder og strømforsyninger er pr bygning.

Examples of multi-building system configurations

	Bygnings / Sektions type	System type	VIDEO / AUDIO	Bolig stationer*1	Dør stationer		Vagt stationer
					GT-DMB-N	Modul type	GT-MKB-N
Multi bygnings område (Side 10)	4 Bolig bygning	A: Standard	VIDEO	40	1	—	1
		B: Udvidet	VIDEO	400	1	—	1
		C: Udvidet	VIDEO	350	1	—	1
		D: Udvidet	VIDEO	270	1	—	1
	2 Hoved bygning	1: Udvidet	VIDEO	—	1	—	3
		2: Udvidet	VIDEO	—	1	—	3
Total				1060	6	0	10
Stor skala Bolig bygninger (Side 12)	3 Bolig setion	A: Udvidet	VIDEO	400	—	—	—
		B: Udvidet	VIDEO	400	—	—	—
		C: Udvidet	VIDEO	300	—	—	—
	1 Hoved sektion	Udvidet	VIDEO	—	3	—	3
Total				1100	3	0	3
Bolig område / Villa med fælles indgange (Side 14)	3 Bolig bygnings / sektion	A: Standard	VIDEO	30	—	—	—
		B: Udvidet	VIDEO	400	1	—	1
		C: Standard	VIDEO	30	—	—	—
	1 Hoved sektion	Standard	VIDEO	—	—	—	1
Total				460	1	0	2

Bus control units		Expanded bus control units		Multi building control unit	Power supply	Lift control adaptor
						
GT-BC	GT-VBC	GT-BCXB-N	GT-VBX	GT-MCX	PS-2420	GTW-LC
1	1 *3	—	—	—	8	×
1	—	—	—	—	8	×
6	6 *3	1	1	—	27	○
6	—	1	—	—	27	○
1	1	—	—	1	7	×
1	—	—	—	1	7	×
6	6	1	1	1	26	○
6	—	1	—	1	26	○
1	1	—	—	1	7	×
1	—	—	—	1	7	×
2	2	1	1	1	22	×
2	—	1	—	1	22	×

*1: Please use a necessary number of GT-4Z / GT-1Z according to system design needs.

*2: Up to 100 GT-1D audio tenant stations can be connected when configuring a standard audio only system.

*3: The number of necessary units varies according to system size.

*Please follow installation manual when designing your system.

Bus kontrol enhed		Udvidet bus kontrol enhed		Multi bygnings kontrol enhed	Strømforsyning
GT-BC	GT-VBC	GT-BCXB-N	GT-VBX	GT-MCX	PS-2420
1	1	0	0	1	4
5	6	1	1	1	9
5	6	1	1	1	9
4	5	1	1	1	8
2	2	1	1	1	7
2	2	1	1	1	7
19	22	5	5	6	44
5	5	1	1	1	7
5	5	1	1	1	7
4	4	1	1	1	6
2	2	1	1	1	8
16	16	4	4	4	28
1	1	0	0	1	2
5	6	1	1	1	9
1	1	0	0	1	2
1	1	0	0	1	3
8	9	1	1	4	16

* 1: Brug venligst et nødvendigt antal GT-4Z / GT-1Z i henhold til systemdesignbehov.

* Følg installationsvejledningen, når du designer dit system.

Udsendt af :



<http://www.aiphone.dk/> <http://www.aiphone.net/>

Deming Prize



Deming Medal



JQA-0291
Corresponding product:
Standard product
Order product



JQA-EM0453
HEADQUARTERS
TOYOTA FACTORY
TAIHOH SITE
DEVELOPMENT CENTER

GT(DK) 2017

Alle rettigheder forbeholdes. Alle udsagn gælder på tidspunktet for udskrivning. Design og specifikationer kan ændres uden varsel til forbedring.

Trykt i Danmark
(DK)