

# PRODUCT DRAWING

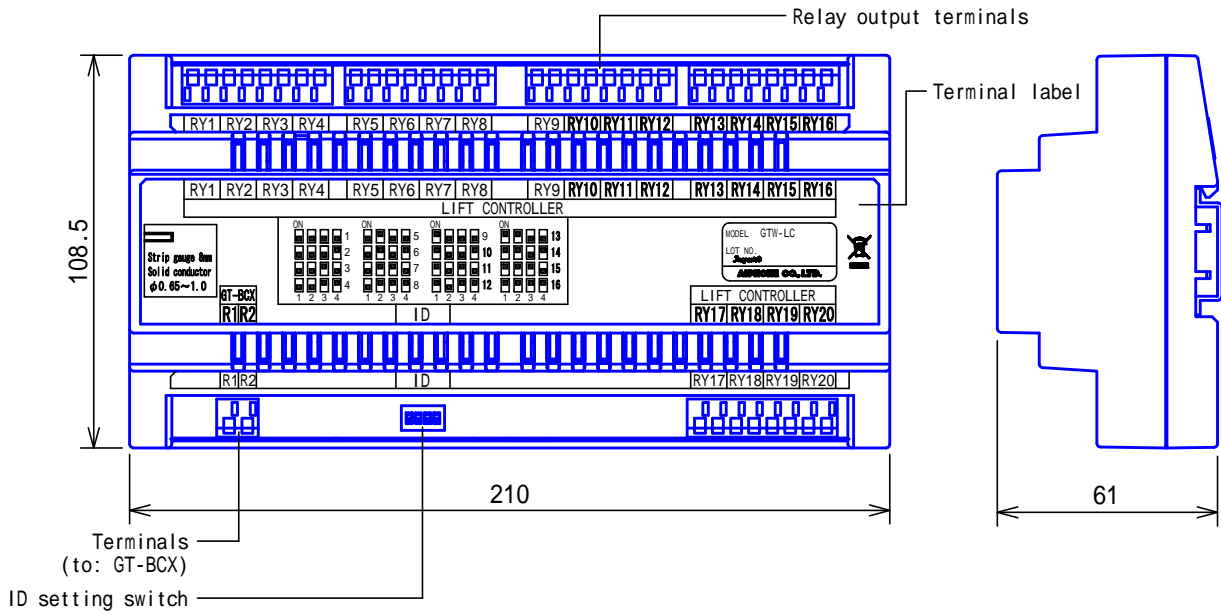

## MOUNTING

- Mounting on wall surface

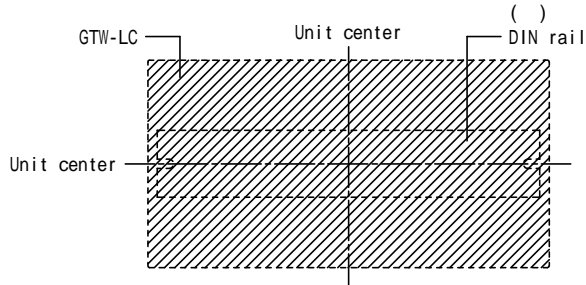

## SPECIFICATIONS

Power source	Supplied from GT-BC
Relay	Output number 20 Contact rating AC/DC 24V, 0.5A Dry contact, Normally open or Normally closed Operating time From 1 second to 600 seconds
Mounting	DIN rail locally available
Housing	Fire-retardant ABS plastic
Unit color	Middle gray (N6.4 Munsell Approximation)
Weight	330g(approx.)
Remarks	Used for: Expanded GT system

DESCRIPTION <b>LIFT CONTROL ADAPTOR</b>	FIG. NAME <b>PRODUCT/SPECIFICATIONS</b>	UNIT mm	DATE 11 March, 2011
MODEL NO. <b>GTW-LC</b>	FIG.NO. G57590-1-2	PAGE 1/2	REVISION 1

**AIPHONE**

## WIRING DIAGRAM

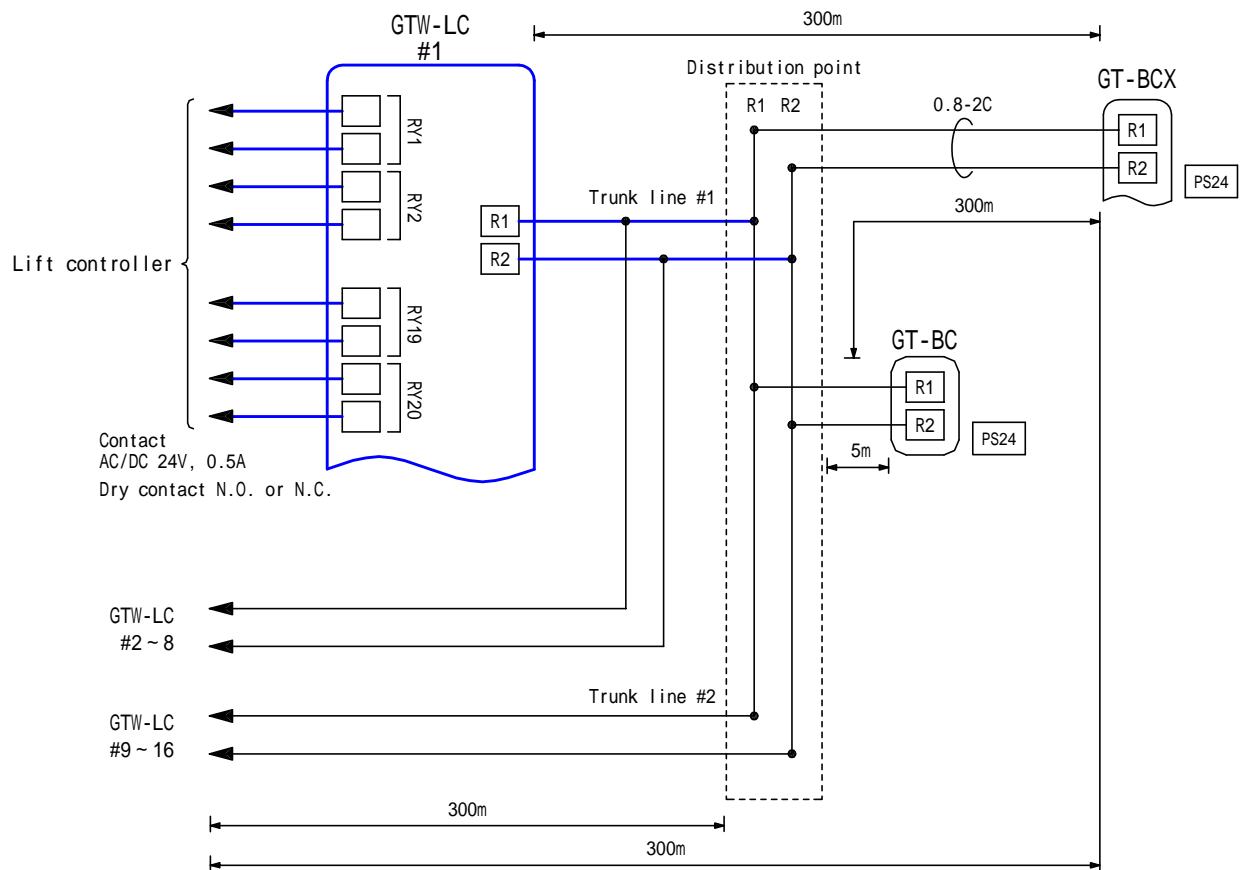

## RESTRICTIONS

Use GT Expanded system with the digital name scrolling entrance station  
 Max. 16 GTW-LC is available to connect in a system (up to 8 GTW-LC per trunk line)  
 In the case of below, GTW-LC do not make/break contact.

- The entrance station access code is input to release the door lock.
- The talk button is pressed and the residential station goes into talk mode while the entrance is being monitored.

## FUNCTIONS

When the door release button is pressed, activate the lift or other systems

## SETTING

- ID setting
- GT system programming with supplied software
  - Output type: Normally open or normally closed
  - Timer: 1 to 600 seconds

DESCRIPTION <b>LIFT CONTROL ADAPTOR</b>	FIG. NAME WIRING/RESTRIC./FUNC./SETTING	UNIT mm	DATE 11 March, 2011
MODEL NO. GTW-LC	FIG.NO. G57590-2-2	PAGE 2/2	REVISION 1
			<b>AIPHONE</b>