

LEM & LEF Series DOOR STATION

Models; **LE-D**, Surface mount
LE-DA, Flush-mount

INSTALLATION & OPERATION MANUAL

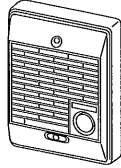

LE-D

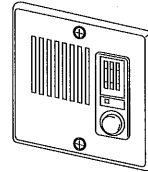

LE-DA

PACKAGE CONTENTS

- Door Station (LE-D or LE-DA)
- Packet of screws
- Installation & Operation Manual



Precautions on Installation

In order for the product to be used safely and properly, please observe the following Precautions.

⚠ WARNING (Negligence could result in death or serious injury.)

When the existing chime wires are used, it is possible that they might carry AC voltage. Locate and disconnect the AC transformer, as it can cause electric shock or damage to the unit. Ask a qualified person to disconnect it. 

⚠ CAUTION (Negligence could result in injury or damage to property.)

- Do not install or make any wire terminations while power supply is plugged in. 
- It may cause electric shock or damage to the unit.
- The door station is weather resistant. However, the unit should not be subjected to high pressure water directed toward it. 

1 SYSTEM OUTLINE & COMPONENTS

Example

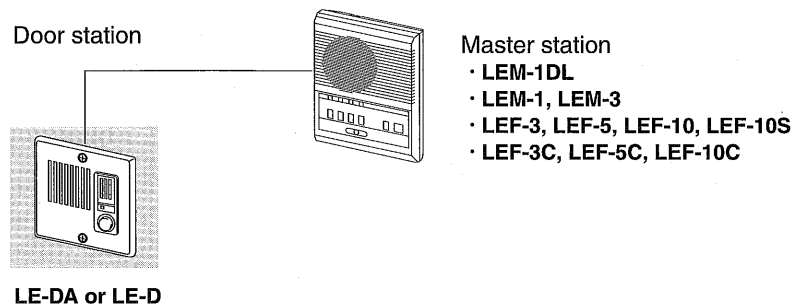

LE-D and LE-DA are weather resistant door stations for use with Aiphone LE Series Open voice intercom systems. Multiple door stations can be integrated within a system. The door stations call the master(s) the same as a standard sub station.

2 NAMES & FEATURES

LE-D

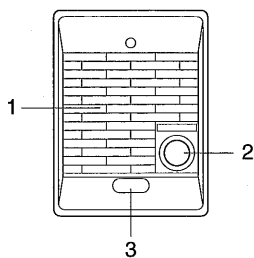

1. Speaker/mic
2. CALL button
3. Mounting screw hole (x2)

LE-DA

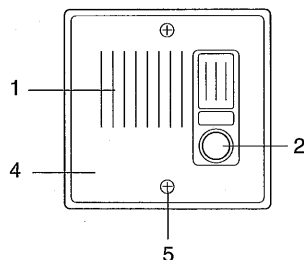

4. Stainless steel cover
5. Screw(x2) for mounting stainless steel cover

FEATURES

- Weather resistant type.
- Signals one or multiple inside master stations.
- 2 wires non-polarized wiring (3 wires in an intermixed system).
- Single-gang wall mounting (LE-D), 2-gang flush-mounting (LE-DA).

3 MOUNTING

LE-D

• Single-gang wall mounting

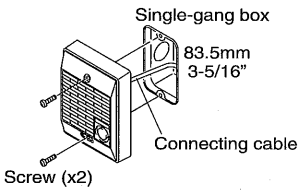

1. Connect 2 wires on back of LE-D.
2. Attach LE-D unit to single-gang box with 2 screws supplied.

• Surface wall mounting

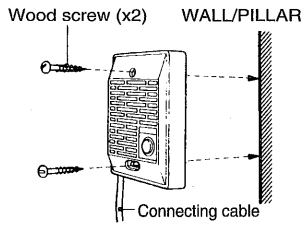

When passing cable through top, make a cable inlet hole as shown.

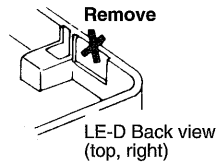

LE-DA

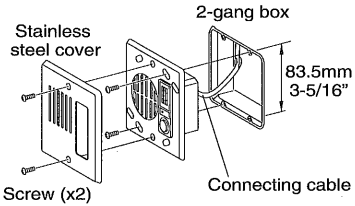

1. Connect 2 wires on back of LE-DA.
2. Separate stainless steel cover, loosening 2 front screws.
3. Attach LE-DA unit to 2-gang box with 2 screws provided.
4. Remount stainless steel cover to LE-DA unit.

4 WIRING

• Selective Calling system (single-master)

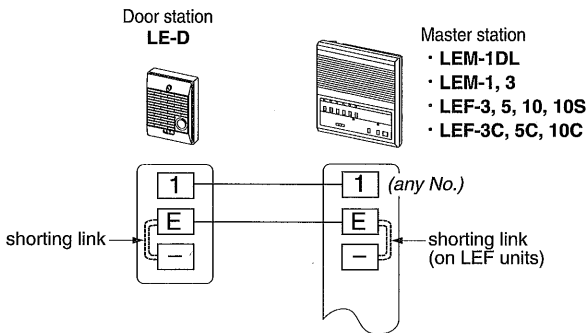

⚠ The shorting link between "E" and "-" terminals remain attached.

• LEF Intermixed system (multiple masters and subs)

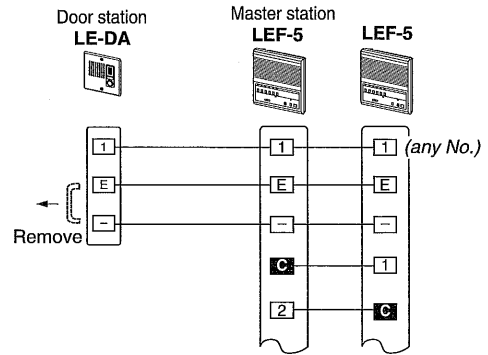

⚠ Remove the shorting link between "E" and "-" terminals at all the LEF master and door/sub stations.

5 OPERATIONS

To call inside station: Momentarily depress CALL button. The call tone rings as long as the button is held down. After the inside station replies, communicate hands free.

6 TECHNICAL PRECAUTIONS

Cleaning

- Clean LE-D or LE-DA unit with a soft cloth dampened with neutral household cleanser. Never use any abrasive cleaner or cloth.

Caulking seals

- Do not apply any caulking seals around the door station. Water drainage holes on the bottom will help water or moisture dissipate.

7 SPECIFICATIONS (LE-D/DA)

- Compatible systems: Any Aiphone LE Series Open voice intercom systems: LEM, LEM-1DL, LEF and LEF-C.
- Communication: Hands free communication at door station, controlled by press-to-talk operation of inside master station.
- Wiring: 2 wires non-polarized (single-master system). E/- jumper remains attached. 3 wires polarized (intermixed system). Remove the jumper on all LE-D/DA's.
- Wiring distance:

Diameter	0.5mm	0.65mm	0.8mm
Distance	120m	200m	300m
AWG	24AWG	22AWG	20AWG
Distance	400'	650'	1000'

- Unit Housing: LE-D: Plastic. LE-DA: Stainless steel cover.
- Dimensions: LE-D: 120(H) x 88(W) x 29(D); 4-3/4"(H) x 3-1/2"(W) x 1-1/8"(D). LE-DA: 115(H) x 116(W) x 10(D); 4-1/2"(H) x 4-9/16"(W) x 3/8"(D). 30mm (1-3/16") recessed.
- Unit weight: LE-D: Approx. 150g (0.33 lbs.). LE-DA: Approx. 205g (0.45 lbs.).

WARRANTY

Aiphone warrants its products to be free from defects of material and workmanship under normal use and service for a period of one year after delivery to the ultimate user and will repair free of charge or replace at no charge, should it become defective upon which examination shall disclose to be defective and under warranty. Aiphone reserves unto itself the sole right to make the final decision whether there is a defect in materials and/or workmanship; and whether or not the product is within the warranty. This warranty shall not apply to any Aiphone product which has been subject to misuse, neglect, accident, or to use in violation of instructions furnished, nor extended to units which have been repaired or altered outside of the factory. This warranty does not cover batteries or damage caused by batteries used in connection with the product. This warranty covers bench repairs only, and any repairs must be made at the shop or place designated in writing by Aiphone. Aiphone will not be responsible for any costs incurred involving on site service calls.

AIPHONE CO., LTD., NAGOYA, JAPAN
AIPHONE CORPORATION, BELLEVUE, WA, USA
AIPHONE EUROPE N.V., ANTWERP, BELGIUM

AIPHONE[®]
Providing Peace of Mind